

ALL Showmanship Beginner

www.horsethows.com

www.horsethows.com

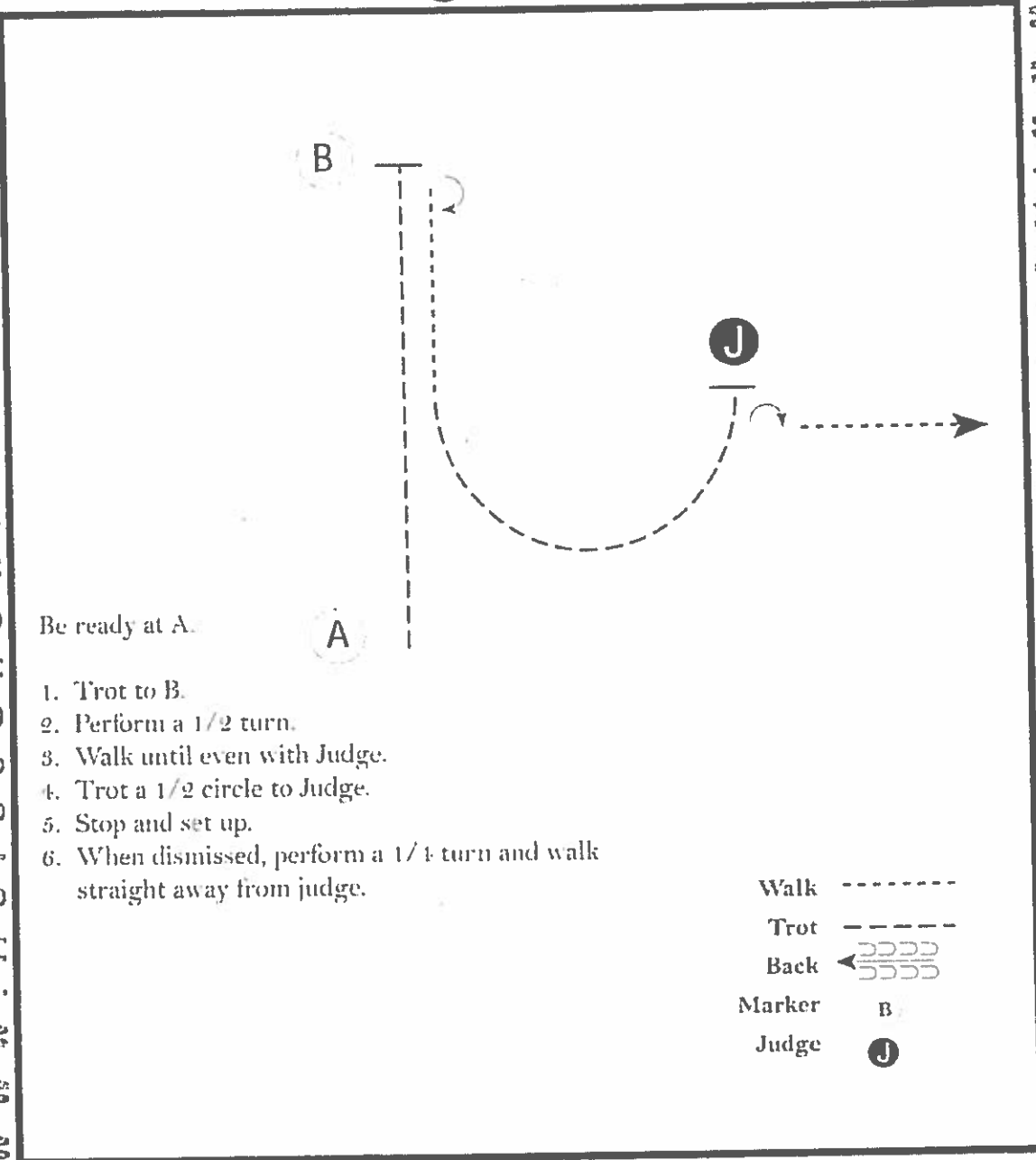

[SWT-73]

Pattern Provided by:

The Judges

Copyright © 2012 The Judges. All Rights Reserved.

ALL Showmanship NOVICE + 13 + U

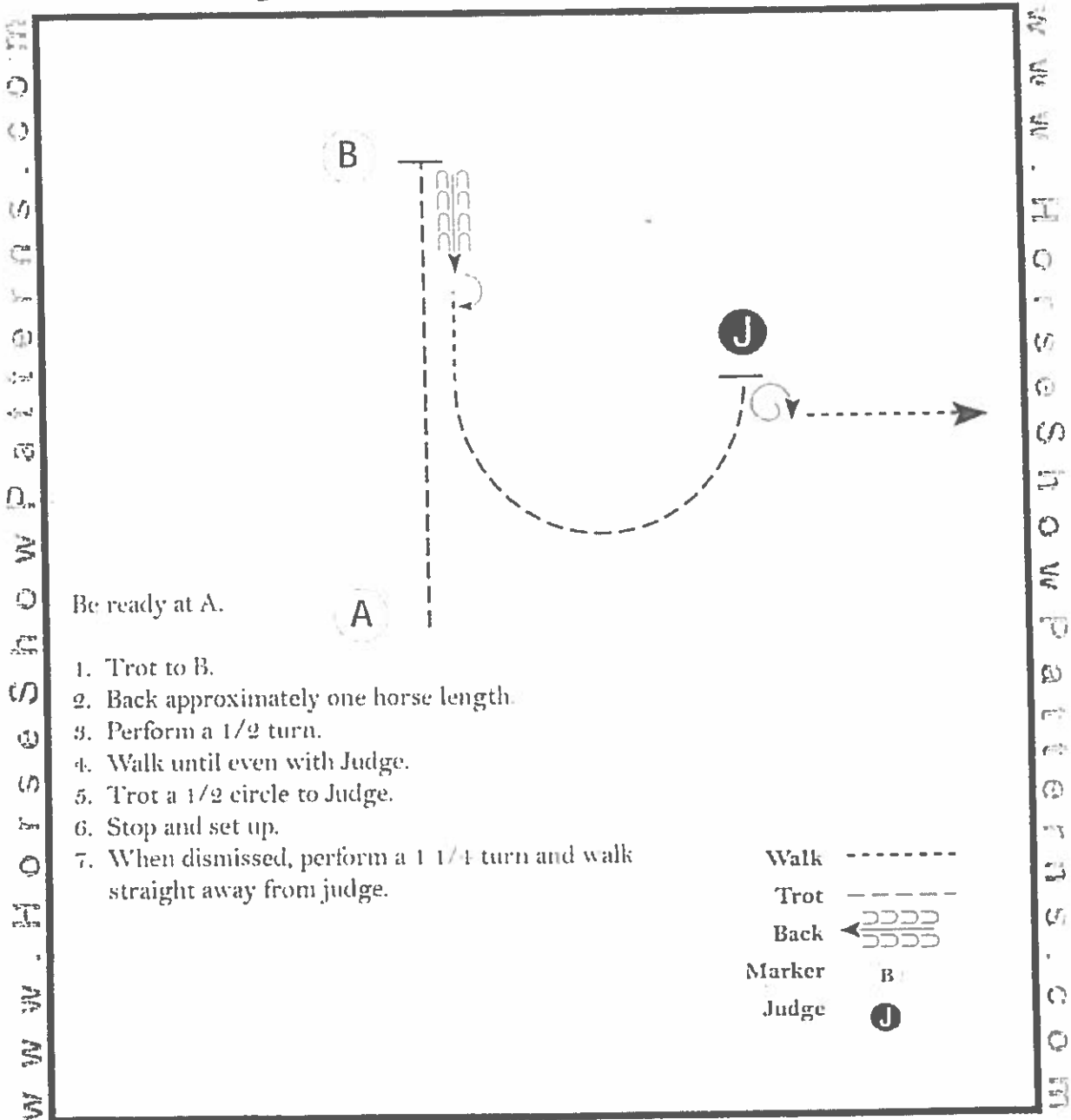

[SI2-73]

Pattern Provided by:
The Judges

©2012 HorseTalkPatterns.com All Rights Reserved

ALL Snowmanship 14-18, 19+over, Open

w w w . H o r s e S h o w P a t t e r n s . c o m

w w w . H o r s e S h o w P a t t e r n s . c o m

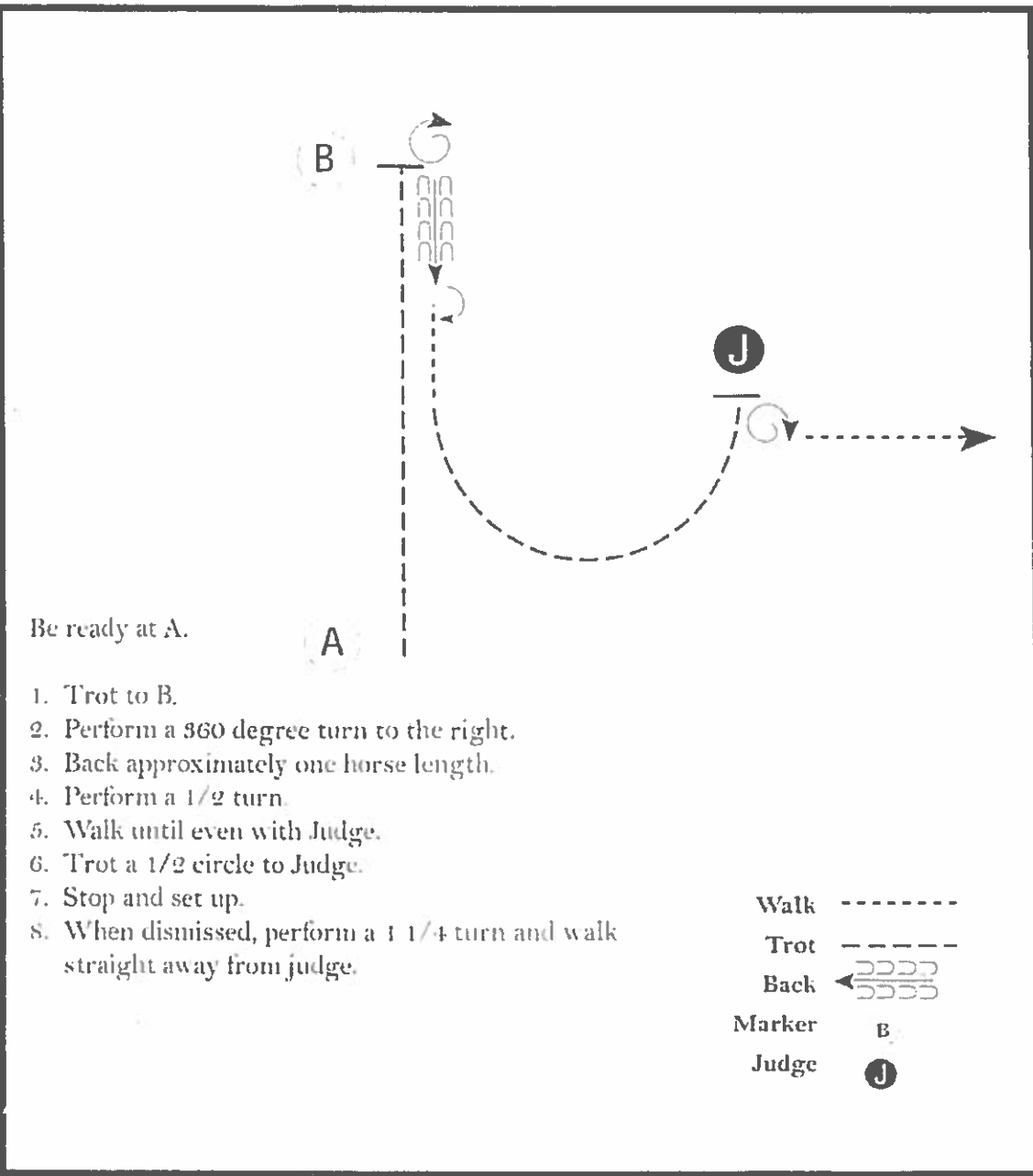

Be ready at A.

1. Trot to B.
2. Perform a 360 degree turn to the right.
3. Back approximately one horse length.
4. Perform a 1/2 turn.
5. Walk until even with Judge.
6. Trot a 1/2 circle to Judge.
7. Stop and set up.
8. When dismissed, perform a 1 1/4 turn and walk straight away from judge.

Walk	-----
Trot	----- d d d d
Back	----- c c c c ←
Marker	B
Judge	J

[S/3-73]

Pattern Provided by:

The Judges

Copyright © 2000 by The Judges

Equitation

NOVICE + B+U

www.horseshowpatterns.com

www.horseshowpatterns.com

Be ready with your horse's tail to A.

1. Walk two horse lengths from A.
2. Canter on the right lead in a half circle to B.
3. Perform a simple lead change at B.
4. Canter a circle to the left at B.
5. Rising trot on the left diagonal until even with A.
6. Turn left and change diagonals.
7. Rising trot on the right diagonal straight away from A.

Pattern is over once you have passed C at the trot.

Follow the directions of your ring steward.

Walk	-----
Trot	- - - - -
Extended Trot	=====
Canter	—————
Lead Change	↔
Back	←
Marker	⌈
Hand Gallop	—————

[HSE/2-46]

Pattern Provided by:

The Judges

Copyright © 2004 by The American Quarter Horse Association

Equitation

14-18, 19+ Over, Open

www.horseshowpatterns.com

www.horseshowpatterns.com

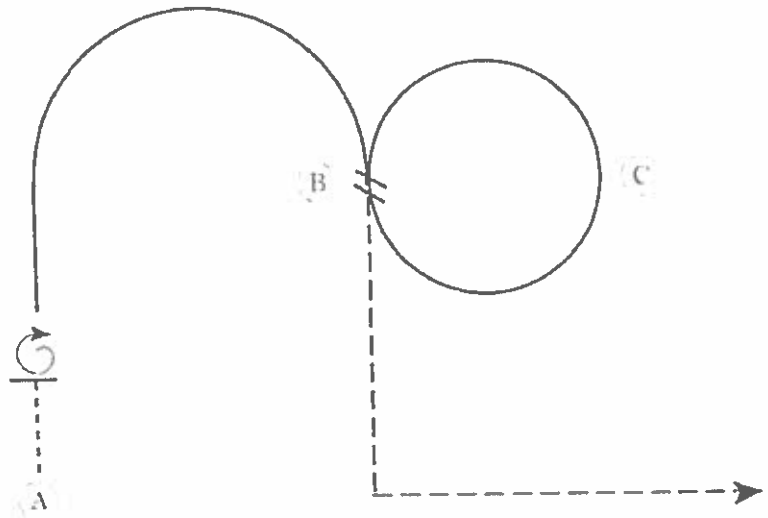

Be ready with your horse's tail to A.

1. Walk two horse lengths from A.
2. Stop and perform a 90 degree turn on the fore hand to the right.
3. Canter on the right lead in a half circle to B.
4. Perform a simple lead change at B.
5. Canter a circle to the left at B.
6. Rising trot on the left diagonal until even with A.
7. Turn left and change diagonals.
8. Rising trot on the right diagonal straight away from A.

Pattern is over once you have passed C at the trot.

Follow the directions of your ring steward.

Walk	-----
Trot	- - - - -
Extended Trot	=====
Canter	—————
Lead Change	↔↔↔↔↔
Back	←←←←←
Marker	⊙
Hand Gallop	—————

[HSE/3-46]

Pattern Provided by:
The Judges

HORSEMANSHIP

NOVICE AND 13 & UNDER

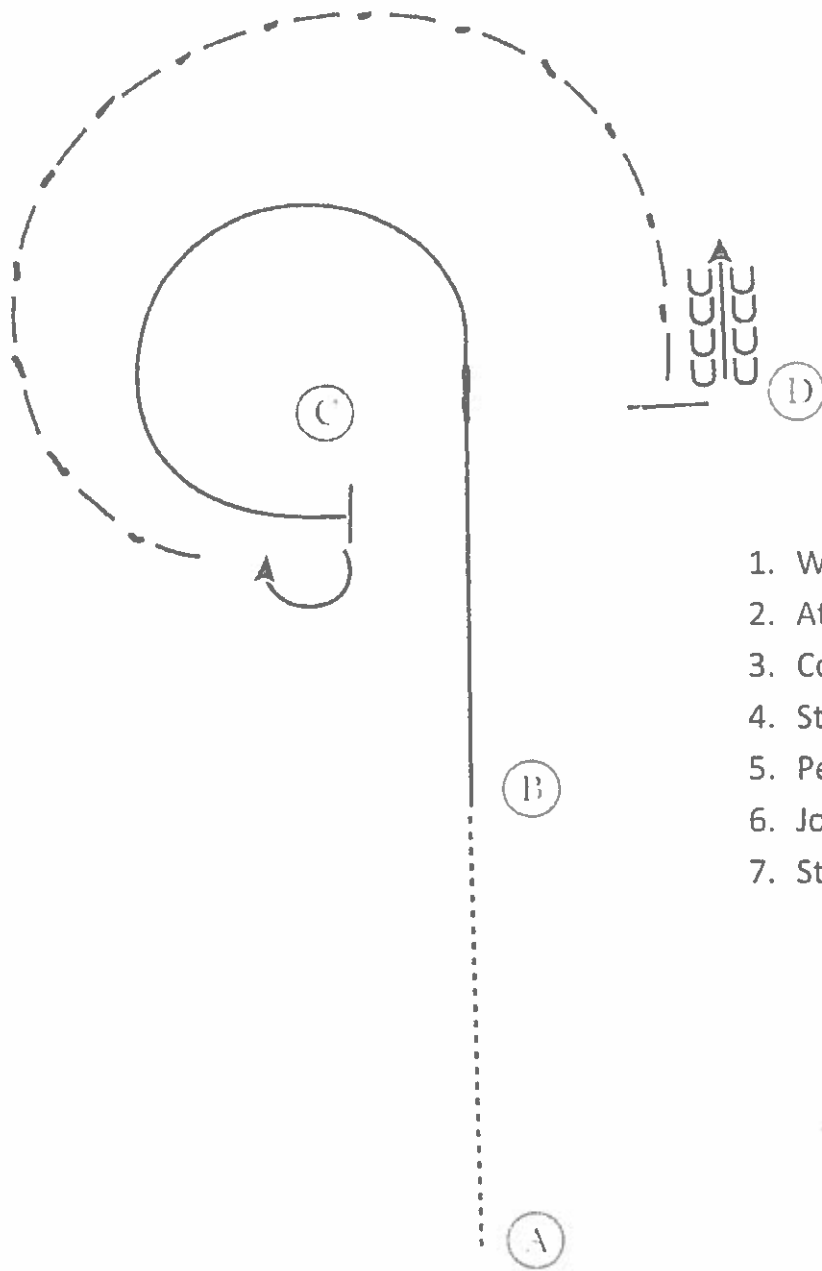

1. Walk A to B.
2. At B lope on left lead
3. Continue on left lead to and around C.
4. Stop at C.
5. Perform 180 degree turn to the right.
6. Jog around C
7. Stop at D and back 4 steps.

Walk
Jog	- - - - -
Extended Jog	— — — — —
Lope	—————
Log Yield	— / — / — / — /
Lead Change	— / — / — / — /
Back	← U U U U U U U U
Marker	(B)
Sidesteps	← - - - - - →

HORSEMANSHIP

14-18, 19 & OVER & OPEN

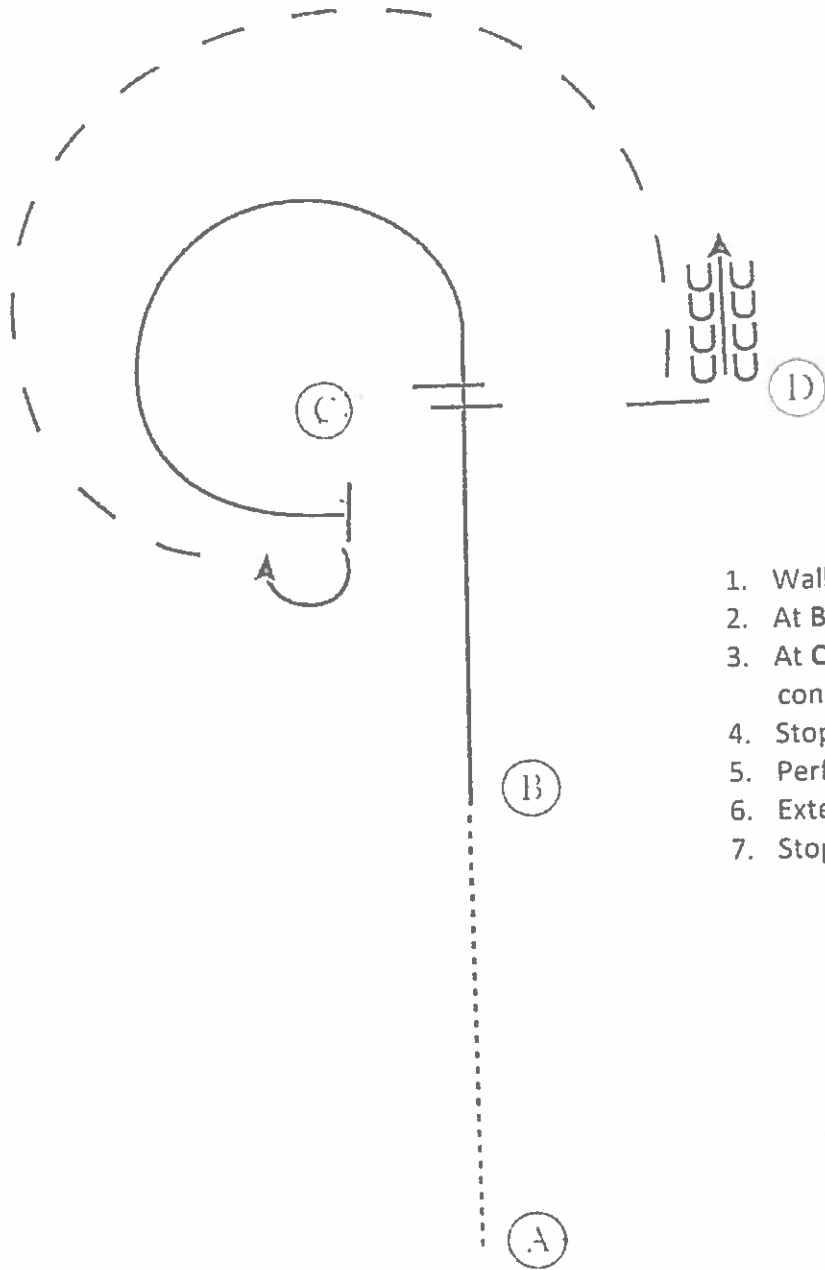

1. Walk A to B.
2. At B lope on the right lead to C.
3. At C perform a lead change and continue on the left lead around C.
4. Stop at C.
5. Perform a 180 degree turn to the right.
6. Extend the jog around C.
7. Stop at D and back 4 steps.

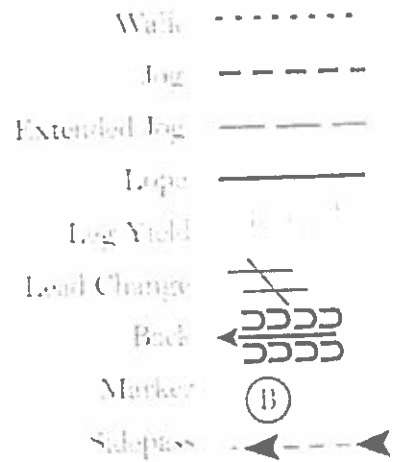

ALL
 18' under
 E
 19' over

RANCH RIDING - PATTERN 2

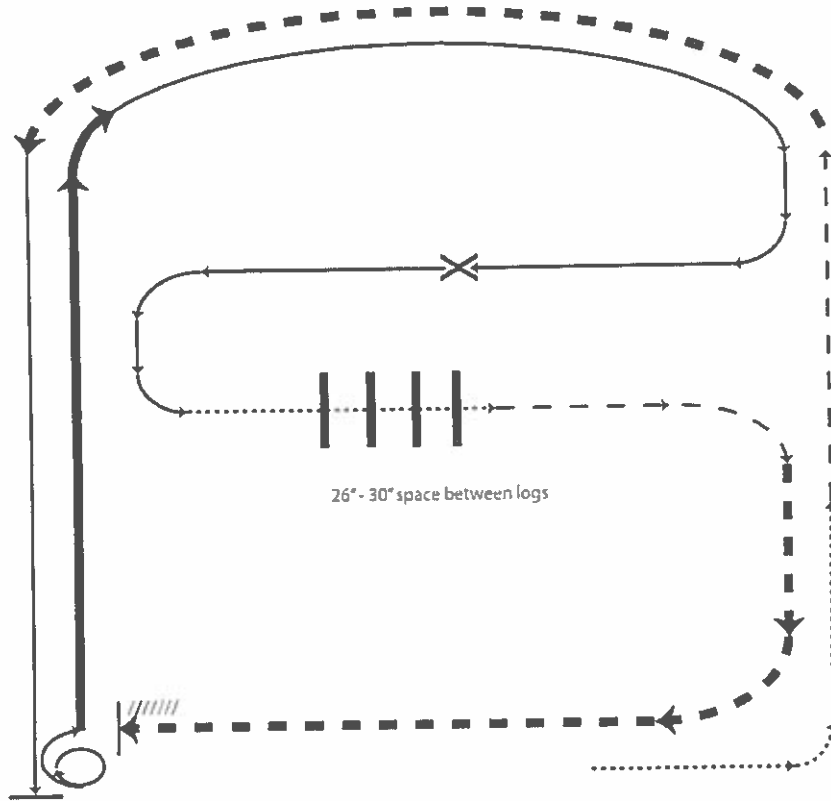

- X Lead Change
- • Walk
- - Trot
- - Ext Trot
- Lope
- Ext Lope
- /////// Back

1. Walk
2. Trot
3. Extended trot
4. Left lead lope
5. Stop, 1 1/2 turn right
6. Extended lope
7. Collect to working lope-right lead
8. Change leads (simple or flying)
9. Walk
10. Walk over logs
11. Trot
12. Extended trot
13. Stop and back

Rolling Hills Saddle Club

Ranch Trail (All Ranch Trail)



www.HorseShowPatterns.com

www.HorseShowPatterns.com

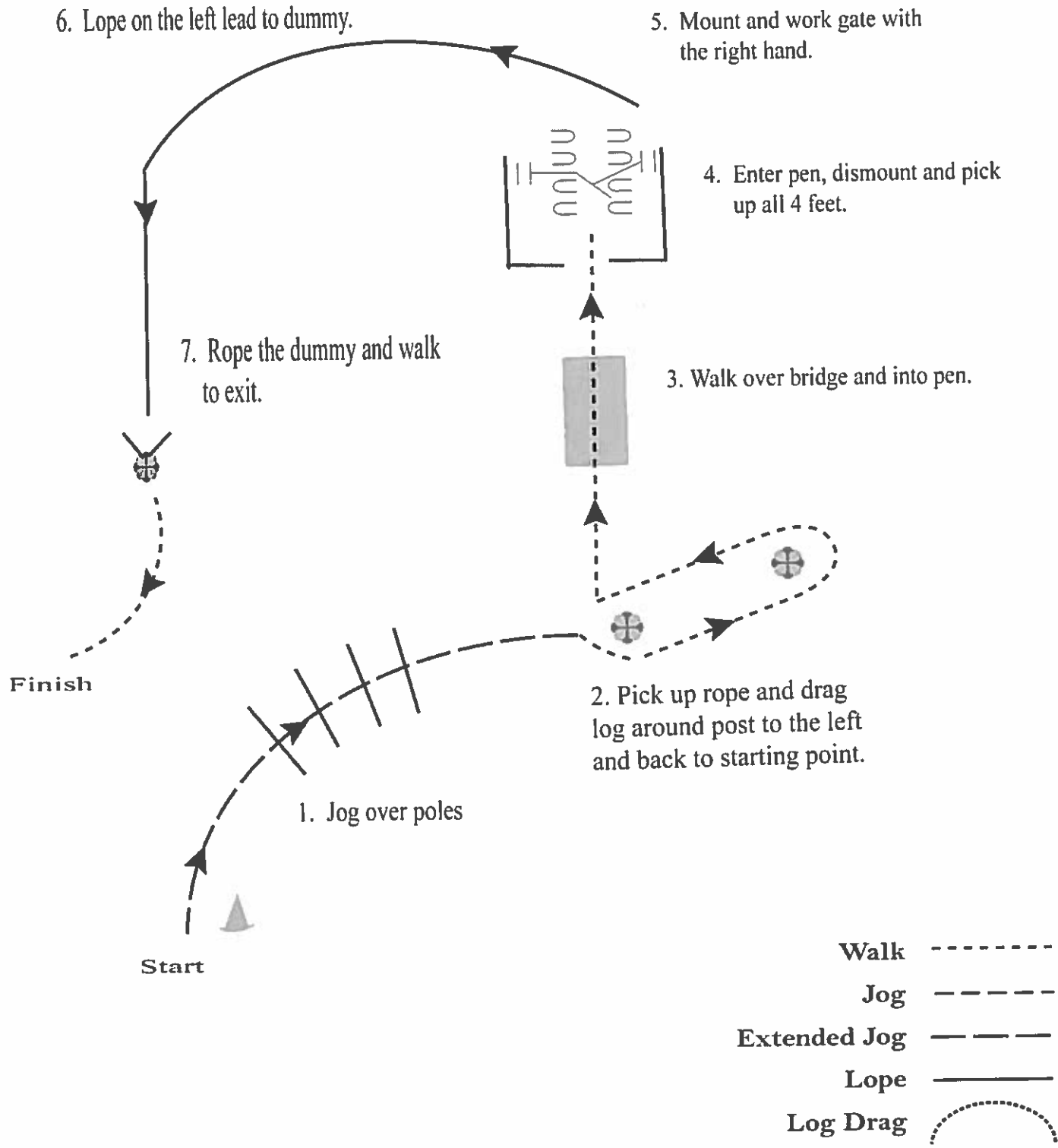

[RT/6]

Pattern Provided by:
Drian Iobell Corcio